

ZNOTES x SAVE MY EXAMS // IGCSE SERIES

www.savemyexams.co.uk

www.znotes.org

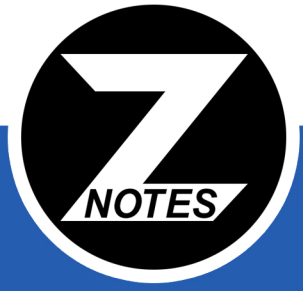

CIE IGCSE MATHS 0580

TOPICAL SOLVED QUESTIONS ON THE SYLLABUS

TABLE OF CONTENTS

2	CHAPTER 1 Numbers
5	CHAPTER 2 Algebra and Graphs
11	CHAPTER 3 Geometry
16	CHAPTER 4 Mensuration (Perimeters, Areas and Volumes)
18	CHAPTER 5 Trigonometry
20	CHAPTER 6 Matrices and Transformations
22	CHAPTER 7 Probability
23	CHAPTER 8 Statistics

save my exams

NOTES

1. NUMBERS

1.1 Integers, HCF/LCM, Prime numbers, Sig Figs, Dec Places

Question 1:

Find the lowest common multiple (LCM) of 36 and 48. [2]

Solution:

We can do this by writing out all of the multiples of the two numbers. The multiples of 36 are:

36, 72, 108, 144, 180, ...

The multiples of 48 are

48, 96, 144, 192, ...

We can see that the lowest common multiple is:

144

1.2 Sets and Venn Diagram

Question 2:

a) $\varepsilon = \{x: 2 \leq x \leq 16, x \text{ is an integer}\}$

$M = \{\text{even numbers}\}$

$P = \{\text{prime numbers}\}$

i) Find $n(M)$. [1]

ii) Write down the set $(P \cup M)'$. [1]

b) On the Venn diagram, shade $A \cap B'$. [1]

Solution:

Part (a)(i)

$n(M)$ is the number of elements in set M . M is all the even numbers between 2 and 16 inclusive which is

$$n(M) = 8$$

Part (a)(ii)

$(P \cup M)'$ are the elements not in the union of sets P and M .

$$(P \cup M) = \{2, 3, 4, 5, 6, 7, 8, 10, 11, 12, 13, 14, 16\}$$

$$(P \cup M)' = \{9, 15\}$$

Part (b)

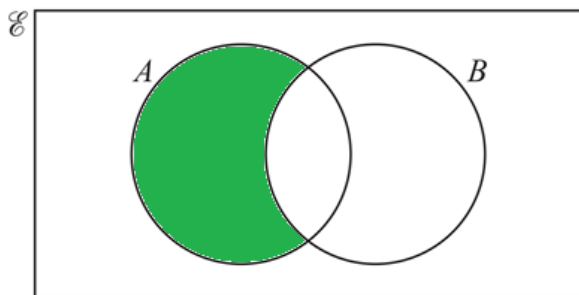

1.3 Square and Cube Numbers

Question 3:

Simplify $(32x^{10})^{\frac{3}{5}}$ [2]

Solution:

Apply the power to everything inside the brackets, and use the general rule that $(a^x)^y = a^{xy}$

$$32^{\frac{3}{5}} \times x^{(10 \times \frac{3}{5})}$$

Note that $32 = 2^5$ hence $32^{\frac{1}{5}} = 2$

$$\begin{aligned} &= \left(32^{\frac{1}{5}}\right)^3 \times x^6 \\ &= 2^3 x^6 \\ &= \mathbf{8x^6} \end{aligned}$$

1.4 Conversion - Percentages, Fractions & Decimals

Question 4:

Write the recurring decimal $0.3\dot{2}$ as a fraction. [2]
[$0.3\dot{2}$ means $0.3222\dots$]

Solution:

We need to get rid of the recurring decimal by doing the following

$$100 \times 0.3\dot{2} = 32.\dot{2}$$

$$10 \times 0.3\dot{2} = 3.\dot{2}$$

$$100 \times 0.3\dot{2} - 10 \times 0.3\dot{2} = 90 \times 0.3\dot{2}$$

$$= 32.\dot{2} - 3.\dot{2}$$

$$\rightarrow 90 \times 0.3\dot{2} = 29$$

Now divide by 90

$$\mathbf{0.3\dot{2} = \frac{29}{90}}$$

1.5 Order by Size

Question 5:

Write the following in order of size, smallest first. [2]

$$\pi \quad 3.14 \quad \frac{22}{7} \quad 3.142 \quad 3$$

Solution:

The order of size can be found by writing all of these numbers out to the same number of decimal places, and then comparing. In order to do this, put each of the values into the same format (decimals) using the 'S \leftrightarrow D' button (located above 'DEL') on your calculator.

$$\pi = 3.14159 \text{ (5. d. p)}$$

$$3.14 = 3.14000 \text{ (5. d. p)}$$

$$\frac{22}{7} = 3.14286 \text{ (5. d. p)}$$

$$3.142 = 3.14200 \text{ (5. d. p)}$$

$$3 = 3.00000 \text{ (5. d. p)}$$

Therefore, the order we get (smallest to largest) is:

$$\mathbf{3 < 3.14 < \pi < 3.142 < \frac{22}{7}}$$

1.6 Standard Form

Question 6:

Write 2.8×10^2 as an ordinary number. [1]

Solution:

We can write 2.8×10^2 as an ordinary number like this:

2.8×10^2 simply means 2.8×100
 $2.8 \times 100 = 280$

1.7 Addition/Subtraction/Multiplication/Division of Fractions & Decimals

Question 7:

Show that

$$1\frac{1}{2} \div \frac{3}{16} = 8$$

Do not use a calculator and show all the steps of your working. [2]

Solution:

This question is most simply done by converting everything to proper fractions. We want to change $1\frac{1}{2}$ into a proper fraction, which can be done as shown.

$$1\frac{1}{2} \rightarrow 1 + \frac{1}{2} \rightarrow \frac{2}{2} + \frac{1}{2} \rightarrow \frac{3}{2}$$

Our problem then becomes

$$\frac{3}{2} \div \frac{3}{16}$$

We can use 'Keep-Change-Flip' to change this to a multiplication problem. We keep $\frac{3}{2}$, change \div into \times , and flip $\frac{3}{16}$ to $\frac{16}{3}$.

$$\frac{3}{2} \times \frac{16}{3}$$

We now can multiply the numerators and denominators.

$$\frac{3 \times 16}{2 \times 3} = \frac{48}{6} = 8$$

Hence $1\frac{1}{2} \div \frac{3}{16} = 8$.

1.8 Estimation

Question 8:

By writing each number correct to 1 significant figure, estimate the value of

$$\frac{\sqrt{3 \cdot 9} \times 29 \cdot 3}{8 \cdot 9 - 2 \cdot 7}$$

Show all your working. [2]

Solution:

Write all numbers correct to one significant figure:

$$\frac{\sqrt{4} \times 30}{9 - 3}$$

Do the calculations.

$$\frac{2 \times 30}{6} = \frac{60}{6}$$

We get the final answer:

10

1.9 Bounds

Question 9:

An equilateral triangle has sides of length 16.1 cm, correct to the nearest millimetre.

Find the lower and upper bounds of the perimeter of the triangle. [2]

Solution:

An equilateral triangle has all sides and angles equal.

We know that each side is 16.1cm to the nearest mm. This means

that, each side could be between 16.15cm and 16.05cm.

We can therefore calculate:

The minimum perimeter/lower bound is:

$$16.05 + 16.05 + 16.05 = 48.15\text{cm}$$

And the maximum perimeter/upper bound is:

$$16.15 + 16.15 + 16.15 = 48.45\text{cm}$$

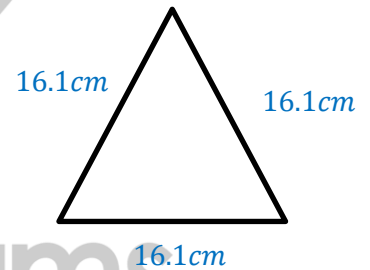

1.10 Ratios

Question 10:

The scale on a map is 1: 20 000.

(a) Calculate the actual distance between two points which are 2.7 cm apart on the map. Give your answer in kilometres. [2]

(b) A field has an area of $64\,400\text{ m}^2$. Calculate the area of the field on the map in cm^2 [2]

Solution:

Part (a)

Multiply the distance on the map by the scale factor to find the real distance in centimeters.

$$\begin{aligned} \text{distance} &= 2.7\text{cm} \times 20\,000 \\ \text{distance} &= 54\,000\text{ cm} \end{aligned}$$

Divide the distance by 100 to get the distance in meters. (1m = 100cm)

$$\text{distance} = 540\text{ m}$$

Divide the real distance in meters by 1000 to get the distance in kilometers (1km = 1000m)

$$\text{distance} = 0.54\text{ km}$$

Part (b)

Multiply the area by 10 000 to get the area in square centimeters.

$$(1\text{m}^2 = 100\text{cm} \times 100\text{cm} = 10\,000\text{ cm}^2)$$

$$\text{area} = 644\,000\,000\text{ cm}^2$$

Divide by the scale factor 20 000² to get the area on the map. (Note: Area scale factor is the square of the length scale factor)

$$\begin{aligned} \text{area on map} &= \frac{644\,000\,000\text{ cm}^2}{(20\,000)^2} \\ \text{area on map} &= 1.61\text{ cm}^2 \end{aligned}$$

1.11 Percentages

Question 11:

In 1970 the population of China was 8.2×10^8 .
In 2007 the population of China was 1.322×10^9 .
Calculate the population in 2007 as a percentage of the population in 1970. [2]

Solution:

The population in 2007 as a percentage of the population in 1970 can be calculated by:

$$\frac{\text{Population in 2007}}{\text{Population in 1970}} \times 100,$$

Substituting in the values gives:

$$\frac{1.322 \times 10^9}{8.2 \times 10^8} \times 100 = 161.21951$$

The answer after rounding is:
161%

1.12 Using a calculator

Question 12:

Use your calculator to find the value of

$$\frac{(\cos 30^\circ)^2 - (\sin 30^\circ)^2}{2(\sin 120^\circ)(\cos 120^\circ)}$$

[2]

Solution:

By inputting the values into your calculator, you get:

$$\frac{(\cos(30))^2 - (\sin(30))^2}{2(\sin(120)(\cos(120)))} = \frac{\frac{3}{4} - \frac{1}{4}}{2 \times \frac{\sqrt{3}}{2} \times \frac{-1}{2}} = \frac{0.5}{\frac{-\sqrt{3}}{2}} = \frac{-\sqrt{3}}{3}$$

So, the answer is:

$$= \frac{-\sqrt{3}}{3}$$

1.13 Time

Question 13:

A train leaves Zurich at 22 40 and arrives in Vienna at 07 32 the next day. Work out the time taken. [1]

Solution:

We can count the time it takes to get us to the Vienna. Add 20 minutes to take it to the next hour:

$$22:40 + 20\text{m} = 23:00$$

Add 1 hour to take it to the next day (24:00 is equivalent to midnight, or 00:00)

$$23:00 + 1\text{hr} = 24:00 (= 00:00)$$

Now add 7 hours and 32 minutes to get to the desired time

$$00:00 + 7\text{hr } 32\text{m} = 07:32$$

The time taken is all the hours and minutes added together like this

$$\begin{aligned} 20\text{m} + 1\text{hr} + 7\text{hr } 32\text{m} \\ \text{Total time} = (8\text{hr } 52\text{m}) \end{aligned}$$

1.14 Currency Conversions

Question 14:

(a) In 2007, a tourist changed 4000 Chinese Yuan into pounds (£) when the exchange rate was £1 = 15.2978 Chinese Yuan. Calculate the amount he received, giving your answer correct to 2 decimal places. [2]

(b) In 2006, the exchange rate was £1 = 15.9128 Chinese Yuan. Calculate the percentage decrease in the number of Chinese Yuan for each £1 from 2006 to 2007. [2]

Solution:

Part (a)

In order to change from Chinese Yuan into pounds, we can do this:

$$\begin{aligned} 1\text{ Chinese Yuan} &= \text{£}0.06537 \\ 4000\text{ Chinese Yuan} &= \text{£}0.06537 \times 4000 \\ 4000\text{ Chinese Yuan} &= \text{£}261.4755 \end{aligned}$$

But we need this to the nearest penny

$$4000\text{ Chinese Yuan} = \text{£}261.4$$

Part (b)

To calculate the percentage decrease we need to do the following:

$$\frac{\text{change in amount of chinese yuan for each £1}}{\text{amount of chinese yuan for each £1 in 2006}} \times 100$$

$$\frac{15.9128 - 15.2978}{15.9128} \times 100 = 3.8648$$

Hence the percentage decrease is **3.865%**

1.15 Finance Problems**Question 15:**

Emily invests \$x at a rate of 3% per year simple interest. After 5 years she has \$20.10 interest. Find the value of x. [3]

Solution:

The equation for simple interest is

$$x + i = x \left(1 + \frac{R}{100} t \right)$$

Where:

- x = Principal investment value
- i = Interest gained
- R = Interest rate (%)
- t = Investment time

$$x + 20.1 = x \left(1 + \frac{3 \times 5}{100} \right)$$

$$1 + \frac{20.1}{x} = 1 + 0.06$$

$$x = \frac{20.1}{0.06}$$

$$x = 134$$

1.16 Finance Problems**Question 16:**

Zainab borrows \$198 from a bank to pay for a new bed. The bank charges compound interest at 1.9% per month. Calculate how much **interest** she owes at the end of 3 months. Give your answer correct to 2 decimal places. [3]

Solution:

To calculate how much interest she owes on \$198 at the end of the 3 months we first must calculate the total amount after interest at the end of the 3 months. This is done as follows:

$$198 \times \left(1 + \frac{r}{100} \right)^3$$

where r is the interest rate. As we know that the interest rate is 1.9%,

$$r = \left(1 + \frac{1.9}{100} \right)^3 = 1.019$$

and hence the total amount after interest is:

$$198 \times 1.019^3 = \$209.50.$$

Hence Zainab owes the bank

$$\$209.5 - \$198 = \$11.5$$

So, the answer is:

$$\mathbf{\$11.5}$$

FOR MORE PAST PAPER QUESTIONS, VISIT

WWW.SAVEMYEXAMS.CO.UK

2. ALGEBRA AND GRAPHS**2.1 Using Algebra to Solve Problems****Question 17:**

Simplify $16 - 4(3x - 2)^2$. [3]

Solution:

Simplifying the equation gives:

$$16 - 4(3x - 2)^2 = 16 - 4(9x^2 - 12x + 4)$$

$$= 16 - 36x^2 + 48x - 16$$

$$= -36x^2 + 48x$$

$$= 12x(4 - 3x)$$

So, the answer is:

$$\mathbf{12x(4 - 3x)}$$

2.2 Factorisation (Linear)

Question 18:

Factorise completely.

a) $2a + 4 + ap + 2p$ [2]

b) $162 - 8t^2$ [2]

Solution:

Part (a)

$$(a + 2)(p + 2)$$

We can check this by expanding it back out:

$$ap + 2p + 2a + 4$$

Part (b)

We can start off by factorising out the common factor of 2

$$2(81 - 4t^2)$$

Then we can see that this is the difference of two squares

$$= 2(9^2 - (2t)^2)$$

$$= 2(9 + 2t)(9 - 2t)$$

2.3 Algebraic fractions

Question 19:

Write as a single fraction in its simplest form. [3]

$$3 - \frac{t + 2}{t - 1}$$

Solution:

Multiply 3 by $\frac{t-1}{t-1}$ to create a common denominator:

$$= \frac{3(t - 1)}{t - 1} - \frac{t + 2}{t - 1}$$

Combine the fractions:

$$= \frac{3t - 3 - (t + 2)}{t - 1}$$

$$= \frac{3t - 3 - t - 2}{t - 1}$$

$$= \frac{2t - 5}{t - 1}$$

2.4 Indices

Question 20:

Simplify $\frac{5}{8}x^{\frac{3}{2}} \div \frac{1}{2}x^{-\frac{5}{2}}$ [2]

Solution:

To simplify the equation, we use the fact that

$$x^a \div x^b = x^{a-b}$$

Hence:

$$\frac{5}{8}x^{\frac{3}{2}} \div \frac{1}{2}x^{-\frac{5}{2}} = \left(\frac{5}{8} \div \frac{1}{2}\right)x^{\frac{3}{2} - \frac{-5}{2}} = \frac{5}{4}x^4$$

So, the answer is:

$$1.25x^4 = 1\frac{1}{4}x^4$$

2.5 Linear equations

Question 21:

Solve the equation.

[2]

$$5 - 2x = 3x - 19$$

Solution:

$$5 - 2x = 3x - 19$$

Add 2x to both sides of the equality:

$$5 = 5x - 19$$

Add 19 to both sides:

$$5x = 24$$

Divide both sides by 5:

$$x = \frac{24}{5}$$

$$x = 4.8$$

2.6 Simultaneous Linear Equations

Question 22:

Solve the simultaneous equations.

[3]

$$0.4x - 5y = 27$$

$$2x + 0.2y = 9$$

Solution:

Rearrange one of the equations to get just x or just y on one side:

$$0.4x = 27 + 5y$$

Substitute this into the second equation:

$$5(27 + 5y) + 0.2y = 9$$

Simplify:

$$135 + 25.2y = 9$$

Solve:

$$25.2y = -126y = -5$$

Substitute your answer into one of the equations:

$$2x - 1 = 9$$

Solve for x:

$$2x = 10x = 5$$

So the answer is:

$$x = 5, y = -5$$

2.7 Linear inequalities

Question 23:

Solve the inequality. [2]
 $3x - 1 \leq 11x + 2$

Solution:

To solve the inequality $3x - 1 \leq 11x + 2$ we must rearrange for x .

$$\begin{aligned}
 3x - 1 &\leq 11x + 2 \\
 -3x &\text{ from both sides} \\
 -1 &\leq 8x + 2 \\
 -2 &\text{ from both sides} \\
 -3 &\leq 8x \\
 \text{Divide both sides by 8} \\
 -\frac{3}{8} &\leq x \\
 \text{Hence we get} \\
 x &\geq -\frac{3}{8}
 \end{aligned}$$

2.7 Quadratic Equations

Question 24:

$y = x^2 + 7x - 5$ can be written in the form $y = (x + a)^2 + b$. Find the value of a and the value of b . [3]

Solution:

If we expand $(x + a)^2$ and collect terms we get
 $y = (x + a)^2 + b$
 $= x^2 + 2ax + a^2 + b$
 If we now compare coefficients of the powers of x we have

$$\begin{aligned}
 CF \ x^1: \ 2a &= 7 \\
 \rightarrow a &= \frac{7}{2} \text{ or } 3.5 \\
 CF \ x^0 \ (\text{units}): \ a^2 + b &= -5 \\
 \rightarrow \frac{49}{4} + b &= -5 \\
 \rightarrow b &= -\frac{20}{4} - \frac{49}{4} \\
 b &= -\frac{69}{4} \text{ or } -17.25
 \end{aligned}$$

2.8 Graphical inequalities

Question 25:

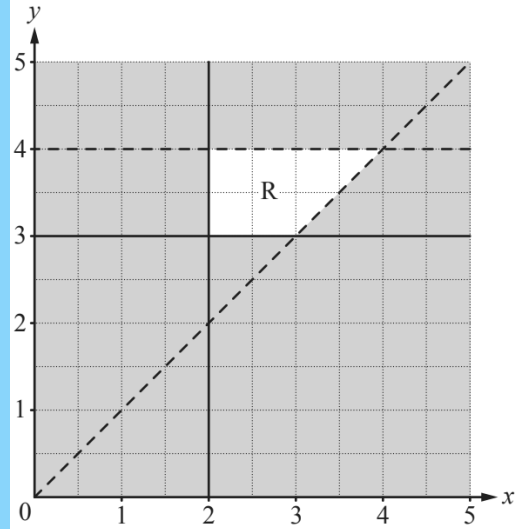

Find four inequalities that define the region, R, on the grid. [4]

Solution:

The lines on the grid that border R are
 $y = 4$
 $y = 3$
 $x = 2$
 $y = x$
 R is above 3 and below 4, to the right of 2 and to the left of the diagonal line. Note that solid lines mean we include them in the inequality. This is written as
 $y < 4$
 $y \geq 3$
 $x \geq 2$
 $y > x$

2.9 Sequences and nth term

Question 26:

Find the nth term of each of these sequences.
 (a) 16, 19, 22, 25, 28, ... [2]
 (b) 1, 3, 9, 27, 81, ... [2]

Solution:

Part (a)
 The difference between the terms is 3. The sequence can then be written as

$$3n + a$$

Where a is some real number and n is the term. The first term is then

$$\begin{aligned}
 3 + a &= 16 \\
 \rightarrow a &= 13
 \end{aligned}$$

Hence

$$\text{nth term} = 3n + 13$$

Part (b)

Each term is a power of 3 so our sequence has the form

$$3^{f(n)}$$

If we substitute in some values, we can see that

$$\begin{aligned} 1 &= 3^{f(1)} \\ \rightarrow f(1) &= 0 \\ 3 &= 3^{f(2)} \\ \rightarrow f(2) &= 1 \end{aligned}$$

Hence

$$f(n) = n - 1$$

Final answer

$$nth \text{ term} = 3^{n-1}$$

2.10 Direct/Inverse proportionality

Question 27:

t varies inversely as the square root of u .

$t = 3$ when $u = 4$.

Find t when $u = 49$.

[3]

Solution:

We are told that t varies inversely with the square root of u . Written mathematically, this says:

$$t \propto \frac{1}{\sqrt{u}}$$

By adding a constant of multiplication we can make this a proper equation:

$$t = \frac{k}{\sqrt{u}}$$

We are given values for t and u , so we can rearrange and solve for k .

$$t = \frac{k}{\sqrt{u}}$$

multiply both sides by \sqrt{u}

$$t\sqrt{u} = k$$

Plugging in values

$$\begin{aligned} 3\sqrt{4} &= k = 3(2) = 6 \\ k &= 6 \end{aligned}$$

Hence our equation becomes

$$t = \frac{6}{\sqrt{u}}$$

We are asked to find t when $u = 49$.

$$t = \frac{6}{\sqrt{49}} = \frac{6}{7}$$

2.11 Kinematics, Distance-Time & Speed-Time Graphs

Question 28:

A car of length 4.3 m is travelling at 105 km/h.

It passes over a bridge of length 36m.

Calculate the time, in seconds, it takes to pass over the bridge **completely**. [3]

Solution:

The car is on the bridge when its front is on the bridge and exits when its rear leaves. The total distance to travel is therefore

$$36 + 4.3 = 40.3m$$

Converting the speed into m/s, first we multiply by 1000 to get the units in m/hr

$$Speed = 105 \text{ kmh}^{-1} \times 1000$$

$$Speed = 105000 \text{ mh}^{-1}$$

Next, we have to turn it into m/s

$$Speed = 105000 \text{ mh}^{-1} \div (60^2)$$

$$Speed = \frac{105000}{3600} \text{ ms}^{-1}$$

$$Speed = \frac{175}{6} \text{ ms}^{-1}$$

Using the speed distance time relation

$$speed = \frac{distance}{time}$$

$$\frac{175}{6} \text{ ms}^{-1} = \frac{40.3m}{time}$$

Rearrange for time

$$\begin{aligned} time &= 40.3 \times \frac{6}{175} \\ &= \mathbf{1.38 \text{ s (2dp)}} \end{aligned}$$

2.11 Constructing Graphs & Solving Equations Graphically

Question 29:

$$f(x) = x - \frac{1}{2x^2}, x \neq 0$$

(a) Complete the table of values. [2]

x	-3	-2	-1.5	-1	-0.5	-0.3	0.3	0.5	1	1.5	2
f(x)	-3.1	-2.1	-1.7		-2.5	-5.9	-5.3	-1.5		1.3	1.9

(b) On the grid, draw the graph of $y = f(x)$ for $-3 \leq x \leq -0.3$ and $0.3 \leq x \leq 2$. [1]

(c) Use your graph to solve the equation $f(x) = 1$ [1]

(d) There is only one negative integer value, k , for which $f(x) = k$ has only one solution for all real x . Write down this value of k . [1]

(e) The equation $2x - \frac{1}{2x^2} - 2 = 0$ can be solved using the graph of $y = f(x)$ and a straight line graph.

i. Find the equation of this straight line [1]

ii. On the grid, draw this straight line and solve the equation $2x - \frac{1}{2x^2} - 2 = 0$. [3]

Solution:

Part (a)

We use calculator to find the values of $f(x)$ for $x=-1$ and $x=1$.

$$f(-1) = -1.5, \quad f(1) = 0.5$$

Part (b)

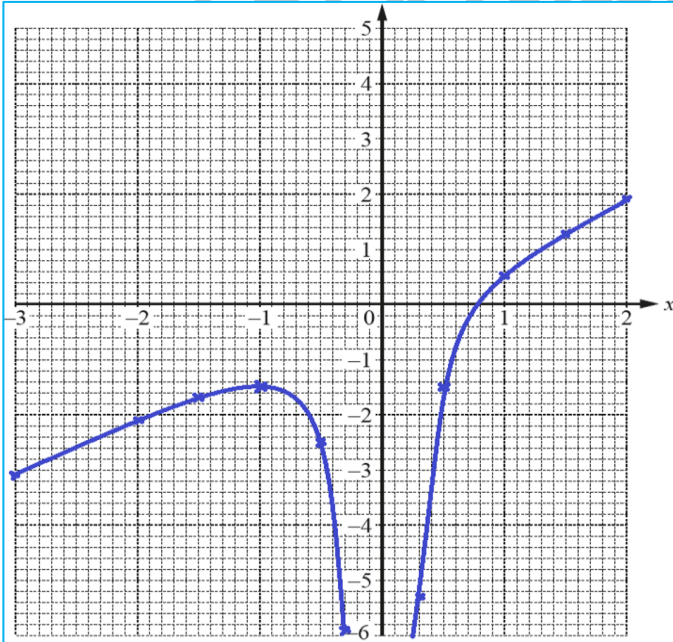

Part (c)

We plot the line $y=1$ and find the x -coordinate of the point of intersection.

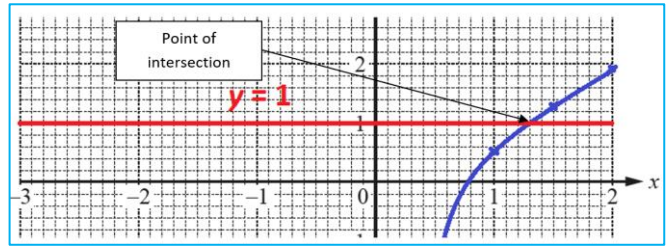

From the graph, we can see that the x -coordinate of the point is

$$x = 1.3$$

Part (d)

From the graph, we can clearly see that $k = -1$, since for -2 and any other negative integer, there are two solutions to $f(x)=k$.

$$k = -1$$

Part (e)(i)

Subtract $(x-2)$ from both sides of the equation.

$$x - \frac{1}{2x^2} = 2 - x$$

We can see that the right side of the equation is our original function.

Therefore, the left-hand side must be the straight line we are looking for.

$$y = 2 - x$$

Part (e)(ii)

We plot a line $y = 2 - x$ and find the x -coordinate of the point of intersection with the original graph to solve

$$2x - \frac{1}{2x^2} - 2 = 0$$

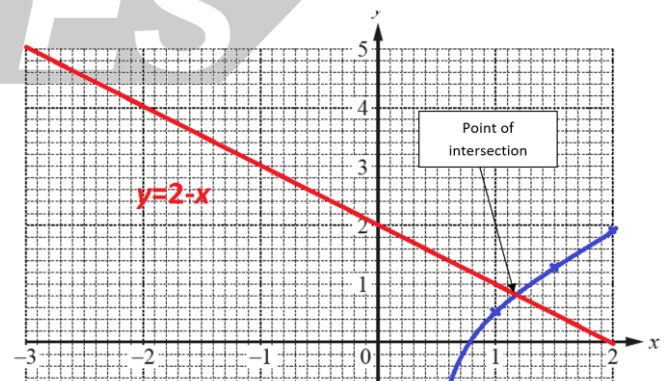

From the graph, we can see that the x -coordinate of the point, and hence the solution to the equation

$$2x - \frac{1}{2x^2} - 2 = 0$$

$$x = 1.15$$

2.11 Tangents & Gradients

Question 30:

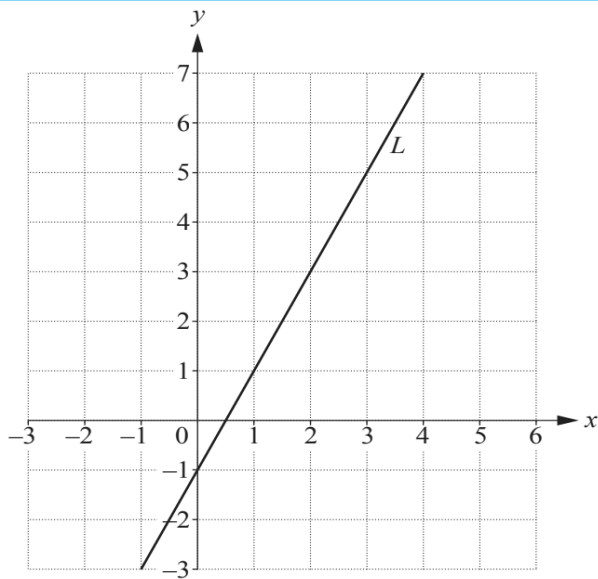

- (a) Work out the gradient of the line L [2]
- (b) Write down the equation of the line parallel to the line L that passes through the point (0, 6). [2]

Solution:

Part (a)

Gradient found by using

$$m = \frac{y_2 - y_1}{x_2 - x_1}$$

Choose the points (1, 1) and (0, -1)

$$m = \frac{1 - (-1)}{1 - 0} = 2$$

Part (b)

Parallel means the same gradient, so 2. This gives us the equation

$$y = 2x + c$$

c is the y intercept which is given as 6

$$y = 2x + 6$$

2.12 Functions

Question 31:

$$f(x) = 5x + 7 \quad g(x) = \frac{4}{x-3}, x \neq 3$$

- (a) Find
 - i. $fg(1)$ [2]
 - ii. $gf(1)$ [2]
 - iii. $g^{-1}(x)$ [2]
 - iv. $ff^{-1}(2)$ [2]
- (b) $f(x) = g(x)$
 - i. Show that $5x^2 - 8x - 25 = 0$ [3]
 - ii. Solve $5x^2 - 8x - 25 = 0$. Show all your working and give your answers correct to 2 decimal places. [4]

Solution:

Part (a)(i)

We apply $f(x)$ to $g(x)$ like so

$$\begin{aligned} fg(x) &= 5g(x) + 7 \\ &= \frac{20}{x-3} + 7 \\ fg(1) &= \frac{20}{1-3} + 7 \\ &= -10 + 7 \\ &= -3 \end{aligned}$$

Part (a)(ii)

We apply the function g to the output of function f giving:

$$\begin{aligned} gf(x) &= \frac{4}{f(x) - 3} \\ &= \frac{4}{5x + 7 - 3} \\ &= \frac{4}{5x + 4} \end{aligned}$$

Part (a)(iii)

Let $y = g(x)$. If we rearrange for $x = f(y)$ then that function of y will be $g^{-1}(y)$.

$$y = \frac{4}{x-3}$$

Multiply both sides by $x - 3$

$$y(x - 3) = 4$$

Divide both sides by y

$$x - 3 = \frac{4}{y}$$

Add 3 to both sides

$$\begin{aligned} x &= \frac{4}{y} + 3 = g^{-1}(y) \\ \rightarrow g^{-1}(x) &= \frac{4}{x} + 3 \end{aligned}$$

Part (a)(iv)

Inverse function applied to the function reverses its effect, so

$$f^{-1}f(2) = 2$$

Part (b)(i)

We have

$$5x + 7 = \frac{4}{x - 3}$$

Multiply both sides by $x - 3$

$$(5x + 7)(x - 3) = 4$$

Expand

$$5x^2 + 7x - 15x - 21 = 4$$

Rearrange and simplify forming a quadratic equation that equals zero:

$$5x^2 - 8x - 25 = 0$$

Part (b)(ii)

We use the quadratic formula, given as

$$x = \frac{-b \pm \sqrt{b^2 - 4ac}}{2a} \quad (\text{where } ax^2 + bx + c = 0)$$

Substitute for

$$a = 5, b = -8, c = -25$$

hence:

$$x = \frac{8 \pm \sqrt{64 + 20 \times 25}}{10}$$

$$= \frac{8 \pm 2\sqrt{141}}{10}$$

$$x = 3.17 \text{ (2. d. p.) or } x = -1.57 \text{ (2. d. p.)}$$

3. GEOMETRY**3.1 Properties of Shapes****Question 32:****Z E B R A**

Write down the letters in the word above that have,

- (a) Exactly one line of symmetry [1]
 (b) Rotational symmetry of order 2 [1]

Solution:**Part (a)**

We can find out which letters in 'ZEBRA' have exactly 1 line of symmetry like this:

Imagine placing a mirror through the centre of each letter at loads of different angles – a line of symmetry is where that mirror would show us the letter we expect to see

For example, if we placed a mirror vertically down the centre of 'A', between the paper and the mirror we would see 'A', so it has a line of symmetry down its centre

This works for E, B and A, so these 3 letters are the answer

Part (b)

Rotational symmetry is found by rotating the letter (from the word 'ZEBRA') around an imaginary point, which we place on one of the corners 'Order 2' means that you could rotate the letter around the imaginary point and it would look the same in 2 different positions (see diagram below)

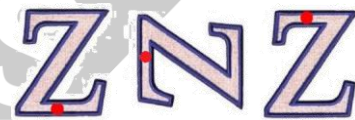

The only letter in 'ZEBRA' for which we can do this is Z – so the answer is Z

FOR MORE PAST PAPER QUESTIONS, VISIT

WWW.SAVEMYEXAMS.CO.UK

3.2 Construction

Question 33:

This diagram shows triangle ABC

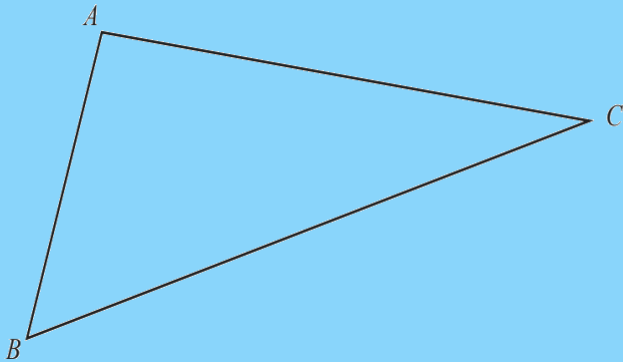

- (a) Using a straight edge and compasses only, construct the bisector of angle ABC. [2]
- (b) Rotational symmetry of order 2 [1]

Solution:

Part (a)

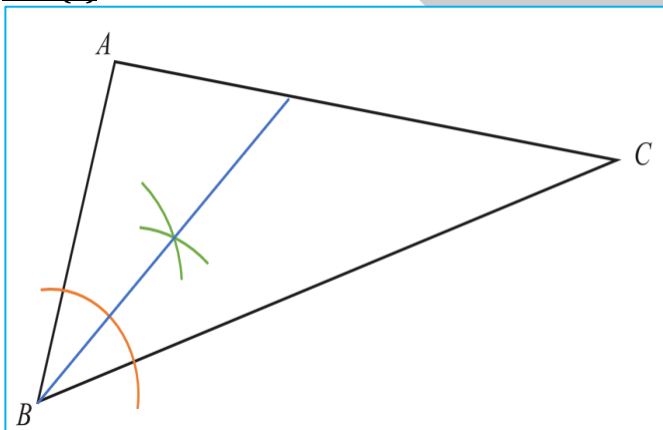

The bisector of angle ABC is drawn in blue. Construction lines are orange and green. You need to use a compass to do this construction and ensure that construction lines are clearly shown.

Part (b)

Using a rule measure carefully 3cm from line AC to construct a parallel line inside the triangle as shown.

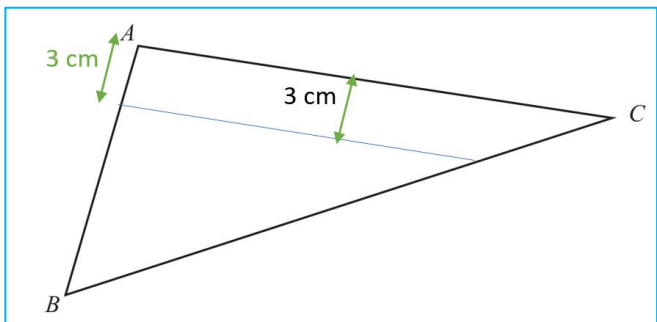

3.3 Similarity

Question 34:

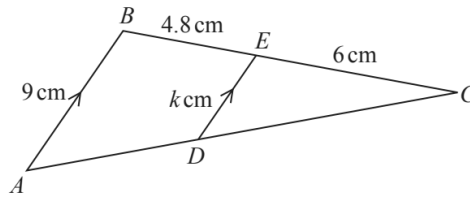

NOT TO SCALE

Triangles CBA and CED are similar.

AB is parallel to DE.

AB = 9 cm, BE = 4.8 cm, EC = 6 cm and ED = k cm.

- (a) Work out the value of k. [2]

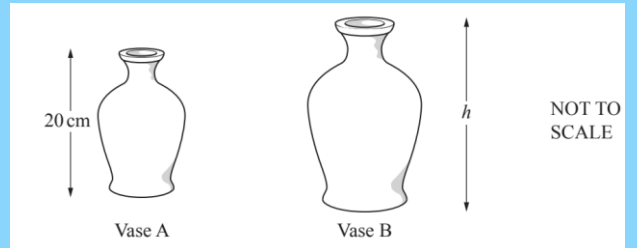

NOT TO SCALE

- (b) The diagram shows two mathematically similar vases.

Vase A has height 20 cm and volume 1500 cm^3 .

Vase B has volume 2592 cm^3 .

Calculate h, the height of vase B. [3]

Solution:

Part (a)

If we imagine that triangle ABC was shortened to create triangle CED then the factor by which CB was shortened to create CE is the same factor that shortened AB to make DE.

$$CB = 10.8$$

$$CE = 6$$

Thus the scale factor is

$$\frac{CE}{CB} = \frac{5}{9}$$

Apply this factor to AB

$$DE = \frac{5}{9} \times AB$$

$$\rightarrow k = 9 \times \frac{5}{9} = 5$$

Part (b)

The volume scale factor is

$$\frac{2592}{1500} = 1.728$$

This is the volume scale factor is the cube of the length (height) scale factor. The height scale factor is therefore

$$\sqrt[3]{1.728} = \frac{6}{5}$$

And hence

$$h_B = \frac{6}{5} \times h_A = 24$$

Part (b)

A line of symmetry is an imaginary line where you can fold the image and have both halves match exactly. Hence by inspection we can see that there are no lines of symmetry as the image will differ if folded over any imaginary line. 6 such examples are shown below:

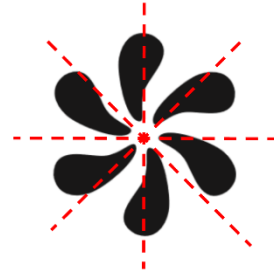

The number of lines of symmetry = 0

3.4 Symmetry (in circles)

Question 35:

This diagram shows triangle ABC

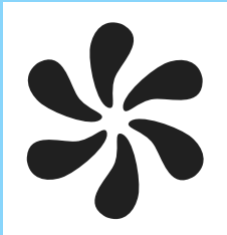

- (a) The order of rotational symmetry [1]
- (b) The number of lines of symmetry [1]

Solution:

Part (a)

The order of rotational symmetry of a shape is the number of times it can be rotated around a full circle and still look the same. Hence by inspection we can see that:

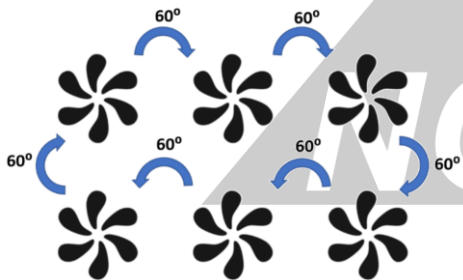

The order of rotational symmetry = 6

3.5 Angles (Circles, Quadrilaterals, Polygons & Triangles)

Question 36:

(a)

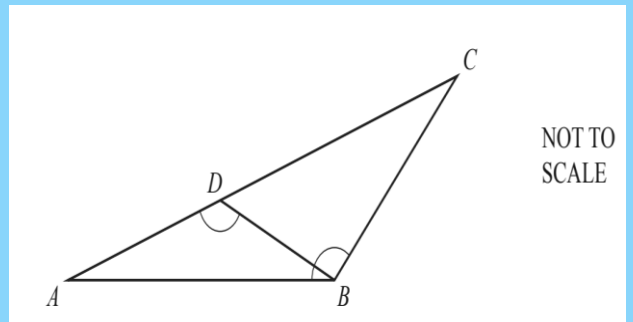

In the diagram, D is on AC so that angle $ADB =$ angle ABC .

- i. Show that angle ABD is equal to angle ACB . [2]
- ii. Complete the statement.
Triangles ABD and ACB are ... [1]
- iii. $AB = 12$ cm, $BC = 11$ cm and $AC = 16$ cm.
Calculate the length of BD . [2]

(b)

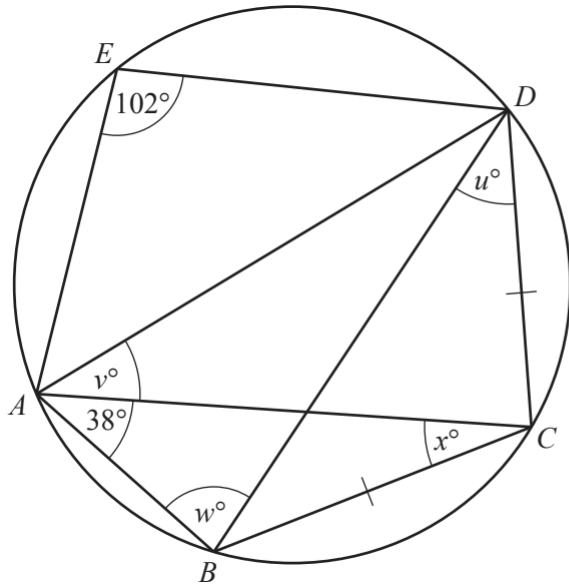

(c) A, B, C, D and E lie on the circle. Angle AED = 102° and angle BAC = 38°. BC = CD. Find the value of

- i. u , [1]
- ii. v , [1]
- iii. w , [1]
- iv. x , [1]

(d)

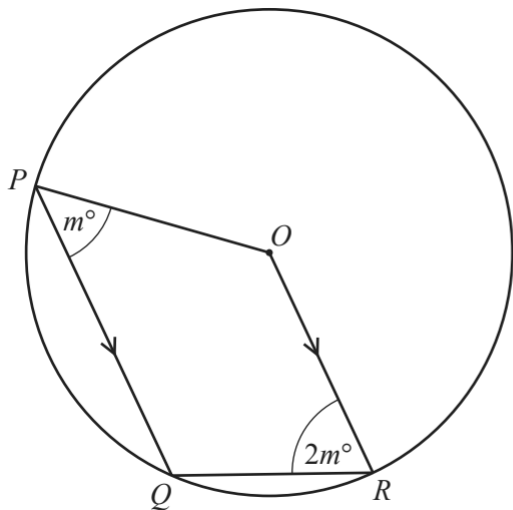

In the diagram, P, Q and R lie on the circle, centre O. PQ is parallel to OR. Angle QPO = m° and angle QRO = $2m^\circ$. Find the value of m . [5]

Solution:

Part (a)(i)

The sum of the interior angles of the two triangles (ABD and ACB) must equal each other (and 180°).

$$ABD + ADB + DAB = ABC + ACB + CAB$$

The angles CAB and DAB are actually one and the same as D line on AC.

$$ABD + ADB = ABC + ACB$$

Angles ADB = angle ABC.

$$\text{Therefore: } \mathbf{ABD = ACB}$$

Part (a)(ii)

As the angles in these two triangles are the same, the triangles ABD and ACB are similar.

...similar

Part (a)(iii)

The angles are similar, therefore the following ratios equal.

$$\frac{BD}{AB} = \frac{BC}{AC}$$

Using the lengths given.

$$\frac{BD}{12 \text{ cm}} = \frac{11 \text{ cm}}{16 \text{ cm}}$$

Multiply both sides by 12cm.

$$BD = \frac{11}{16} \times 12 \text{ cm}$$

$$\mathbf{BD = 8.25 \text{ cm}}$$

Part (b)(i)

The angle BDC is subtended by the same points (B and C) as the angle BAC, so they must be the same size.

(Angles in the same segment are equal)

Therefore

$$\mathbf{u^\circ = 38^\circ}$$

Part (b)(ii)

As the length of BC and CD are equal, so the angles BAC and CAD are also equal.

Hence:

$$\mathbf{v^\circ = 38^\circ}$$

Part (b)(iii)

Opposite angles of a cyclic quadrilateral add up to 180° . In this case, the opposite angles are AED and ABD.

$$180^\circ = AED + ABD$$

$$180^\circ = 102^\circ + w^\circ$$

Subtract 102° from both sides of the equation.

$$\mathbf{w = 78^\circ}$$

Part (b)(iv)

The interior angles of any triangle ABC sum to 180° .
The triangle BCD is an isosceles triangle, therefore angles DBC and BDC have the same size 38° .

$$180^\circ = ABC + BCA + CAB$$

$$180^\circ = (w^\circ + u^\circ) + x^\circ + 38^\circ$$

$$180^\circ = (38^\circ + 78^\circ) + x^\circ + 38^\circ$$

Subtract 154° from both sides of the equation gives:

$$x^\circ = 26^\circ$$

Part (c)

The sum of all interior angles of a quadrilateral is 360° .

$$360^\circ = PQR + QRO + ROP + OPQ$$

Two of these angles are known. $POQ = m^\circ$ and $QRO = 2m^\circ$
All length OP, OQ and OR must be equal as they are all radii of the circle.
This means that angles POQ and QOR are equilateral triangles.

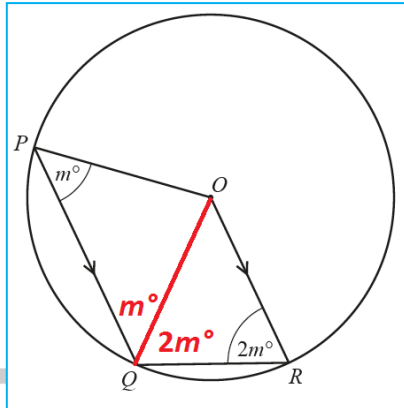

Therefore we know that the angle OPQ and OQP are the same and also OQR is the same as ORQ.

By summing OQP and OQR, we get the size of angle PQR.

$$PQR = OQP + OQR = OPQ + ORQ$$

$$PQR = m^\circ + 2m^\circ = 3m^\circ$$

As the lines PQ and OR are parallel, the sum of angles at P and O must be the same as the sum of angles at Q and R.

$$ROP + OPQ = PQR + QRO$$

$$ROP + m^\circ = 3m^\circ + 2m^\circ$$

Subtract m° from both sides to get the value of ROP.

$$ROP = 4m^\circ$$

Now we know all four angles of the original equation.

$$360^\circ = 3m^\circ + 2m^\circ + 4m^\circ + m^\circ$$

$$360^\circ = 10m^\circ$$

Divide both sides by 10 to work out the value of m .

$$m = 36^\circ$$

3.6 Loci

Question 37:

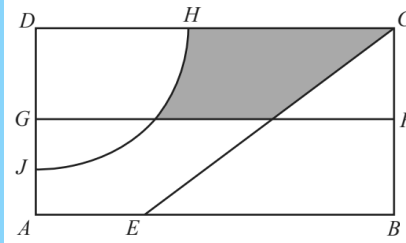

NOT TO SCALE

The diagram shows a rectangular garden divided into different areas.

FG is the perpendicular bisector of BC.

The arc HJ has centre D and radius 20 m.

CE is the bisector of angle DCB.

Write down two more statements using loci to describe the shaded region inside the garden. [2]

Solution:

The shaded region is

- nearer to C than to B
- more than 20m from D
- closer to CD than CB



FOR MORE PAST PAPER QUESTIONS, VISIT

WWW.SAVEMYEXAMS.CO.UK



4. MENSURATION (PERIMETERS, AREAS & VOLUMES)

4.1 2D Shapes: Perimeters & Areas

Question 38:

The base of a triangle is 9 cm correct to the nearest cm. The area of this triangle is 40 cm² correct to the nearest 5 cm². Calculate the upper bound for the perpendicular height of this triangle. [3]

Solution:

The area of a triangle is

$$A = \frac{1}{2} \times \text{base} \times \text{height}$$

Here we have

$$\sim 40 = \frac{1}{2} \times \sim 9 \times h$$

For the upper bound on height we need the area to be as large as possible and the base to be as short as possible, i.e.

$$\begin{aligned} A &= 42.5 \\ b &= 8.5 \end{aligned}$$

Hence

$$\begin{aligned} 42.5 &= \frac{1}{2} \times 8.5 \times h \\ h &= 10 \end{aligned}$$

4.2 Circle Problems (Area, Circumference, Arcs)

Question 39:

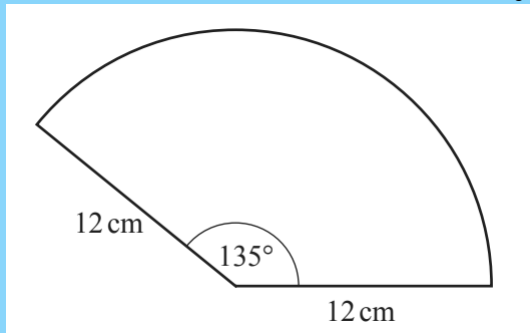

The diagram shows a sector of a circle of radius 12 cm with an angle of 135°.

Calculate the perimeter of the sector. [3]

Solution:

Here we can use fractions to calculate the perimeter of the sector.

We know that a circle has a total angle of 360°, and here we are looking at a sector of angle 135°. Hence the fraction of the circle we are looking at is

$$\frac{135}{360} = \frac{3}{8}$$

Now we want the perimeter of the total circle – this is an equation you should have memorised.

$$\text{perimeter} = \text{circumference} = 2\pi r$$

Now we only want the fraction we found of this total result, so we can multiply the two.

$$\text{arc perimeter} = \frac{3}{8} \times 2\pi r = \frac{3}{4}\pi r$$

We are given $r = 12\text{cm}$. We need to remember that the perimeter of this shape also includes two radii, (i.e. Arc length plus two straight sections (radii)). Hence our total perimeter becomes:

$$\text{total perimeter} = \frac{3}{4}\pi r + r + r = \frac{3}{4}\pi r + 2r$$

$$\begin{aligned} \text{total perimeter} &= \frac{3}{4}\pi(12) + 2(12) \\ &= 52.3\text{cm} \end{aligned}$$

4.3 3D Shapes: Volumes & Surface Areas

Question 39:

The diagram shows a solid hemisphere.

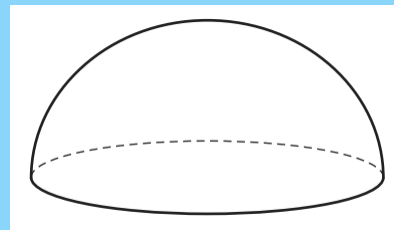

The **total** surface area of this hemisphere is 243π .

The volume of the hemisphere is $k\pi$.

Find the value of k .

[The surface area, A , of a sphere with radius r is $A = 4\pi r^2$.]

[The volume, V , of a sphere with radius r is $V = \frac{4}{3}\pi r^3$.]

[4]

Solution:

The surface area of a hemisphere (blue) is half that of a sphere **plus** the area of the circle (red):

$$\frac{1}{2} \times 4\pi r^2 + \pi r^2 = 3\pi r^2$$

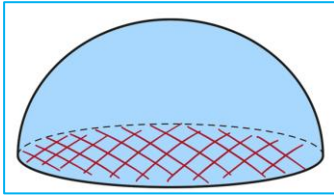

Equate this to the surface area of this hemisphere to find the radius, r :

$$\begin{aligned} 3\pi r^2 &= 243\pi \\ r^2 &= 81 \\ r &= 9 \end{aligned}$$

The volume of a hemisphere is half that of a sphere:

$$V_{\text{hemisphere}} = \frac{1}{2} \times \frac{4}{3}\pi r^3 = \frac{2}{3}\pi r^3$$

Equate this to the volume of this hemisphere:

$$\frac{2}{3}\pi r^3 = k\pi$$

Cancel out the π and substitute $r = 9$:

$$\begin{aligned} \frac{2}{3} \times 9^3 &= k \\ k &= 486 \end{aligned}$$

Part (a)

Length of a line is given by

$$\sqrt{(y_2 - y_1)^2 + (x_2 - x_1)^2}$$

Here, that is

$$\begin{aligned} &\sqrt{(13 + 5)^2 + (4 + 2)^2} \\ &= \sqrt{324 + 36} \\ &= 18.97 \end{aligned}$$

Part (b)

The gradient of the line can be found as

$$\begin{aligned} m &= \frac{y_2 - y_1}{x_2 - x_1} \\ &= \frac{13 + 5}{4 + 2} \\ &= 3 \end{aligned}$$

Using the straight-line equation

$$y - y_1 = m(x - x_1)$$

With our gradient and the point B we get

$$\begin{aligned} y - 13 &= 3(x - 4) \\ \rightarrow y &= 3x - 12 + 13 \\ \rightarrow y &= 3x + 1 \end{aligned}$$

Part (c)

Parallel means it has the same gradient. This new line, using the same straight-line equation as before, is

$$\begin{aligned} y + 5 &= 3(x - 0) \\ \rightarrow y &= 3x - 5 \end{aligned}$$

Part (d)

Perpendicular bisector means that it has a perpendicular gradient to line AB and it cuts through the midpoint. The perpendicular gradient is

$$\begin{aligned} &-1 \div 3 \\ &= -\frac{1}{3} \end{aligned}$$

The midpoint is

$$\begin{aligned} M &= \left(\frac{4 - 2}{2}, \frac{13 - 5}{2} \right) \\ &= (1, 4) \end{aligned}$$

The perpendicular bisector then has the equation

$$\begin{aligned} y - 4 &= -\frac{1}{3}(x - 1) \\ \rightarrow 3y - 12 &= -x + 1 \\ \rightarrow x + 3y - 13 &= 0 \end{aligned}$$

4.3 Co-ordinate Geometry

Question 39:

Equations of a Line (gradients, mid-points, perpendicular & parallel lines)

A line joins the points A (-2, -5) and B (4, 13).

(a) Calculate the length AB [3]

(b) Find the equation of the line through A and B. Give your answer in the form $y = mx + c$. [3]

(c) Another line is parallel to AB and passes through the point (0, -5).

Write down the equation of this line. [2]

(d) Find the equation of the perpendicular bisector of AB. [5]

FOR MORE PAST PAPER QUESTIONS, VISIT
WWW.SAVEMYEXAMS.CO.UK

5. TRIGONOMETRY

5.1 Bearings

Question 38:

A helicopter flies from its base B to deliver supplies to two oil rigs at C and D .
 C is 6 km due east of B and the distance from C to D is 8 km.
 D is on a bearing of 120° from B .

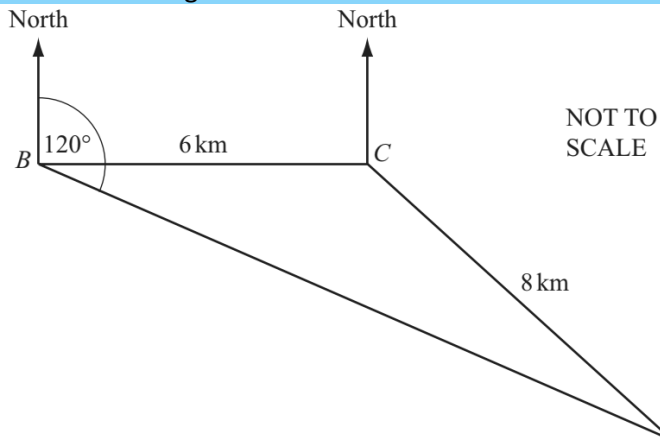

Find the bearing of D from C . [5]

Solution:

To find the bearing of D from C we'll need to find the size of the angle BCD , and then take that angle, and 90° , away from 360° . This is going to require us to use the 'Sine Rule' to find out the angles inside the triangle. The 'Sine Rule' can be used to find either the length of a side of a triangle, or an angle in a triangle – it goes like this:

$$\frac{a}{\sin A} = \frac{b}{\sin B} = \frac{c}{\sin C}$$

$$\text{Angle } DCB = 120^\circ - 90^\circ = 30^\circ$$

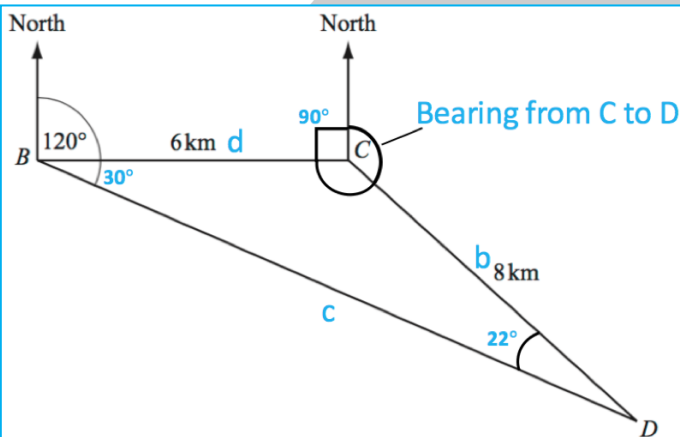

So, applying the Sine rule:

$$\frac{8}{\sin 30} = \frac{6}{\sin D}$$

$$\sin D \left(\frac{8}{\sin 30} \right) = 6$$

$$\sin D = \frac{6}{\left(\frac{8}{\sin 30} \right)}$$

$$D = \sin^{-1} \left(\frac{6}{\left(\frac{8}{\sin 30} \right)} \right)$$

$$D = 22.0^\circ$$

All angles within a triangle add up to 180° , so

$$BCD = 180 - 30 - 22$$

$$BCD = 128^\circ$$

$$\text{Bearing from } C \text{ to } D = 360 - 90 - 128 = 142^\circ$$

5.2 2D Pythagoras & Trigonometry (SOHCAHTOA)

Question 39:

This diagram shows triangle ABC

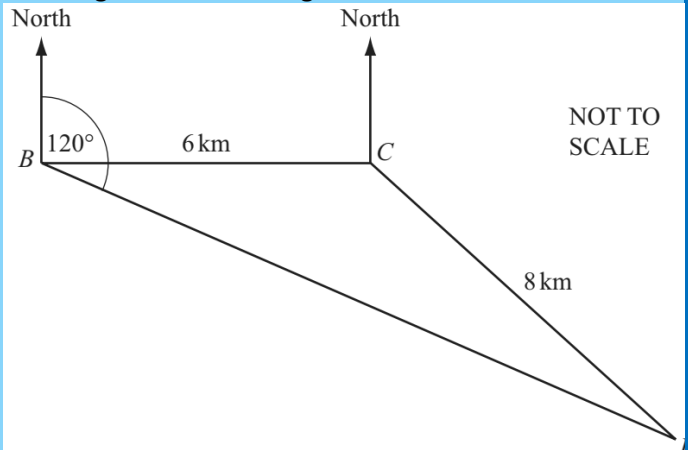

- (a) Andrei stands on level horizontal ground, 294 m from the foot of a vertical tower which is 55 m high.
- Calculate the angle of elevation of the top of the tower. [2]
 - Andrei walks a distance x metres directly towards the tower. The angle of elevation of the top of the tower is now 24.8° . Calculate the value of x . [4]

Solution:

Part (a)(i)

The angle of elevation can be calculated using trigonometry.

$$\tan(\text{angle}) = \frac{55}{294}$$

Take \tan^{-1} of both sides of the equation to calculate the angle of elevation.

$$\begin{aligned} \text{angle} &= \arctan\left(\frac{55}{294}\right) \\ \text{angle} &= 10.6^\circ \end{aligned}$$

Part (a)(ii)

We use the same formula as before, but now we subtract x from Anderi's original distance from the tower (294m).

$$\tan(24.8^\circ) = \frac{55}{294 - x}$$

Invert both fractions.

$$\frac{1}{\tan(24.8^\circ)} = \frac{294 - x}{55}$$

Multiply both sides by 55m.

$$\frac{55m}{\tan(24.8^\circ)} = 294 - x$$

Subtract 294m from both sides of the equation.

$$x = 294m - \frac{55}{\tan(24.8^\circ)}$$

Use a calculator to work out the value of x .

$$x = 175m$$

Part (b)

Using the cosine rule

$$\begin{aligned} c^2 &= a^2 + b^2 - 2ab \cos C \\ c^2 &= 100 + 49 - 140 \cos 35 \\ c^2 &= 34.3 \\ c &= \sqrt{34.3} \\ c &= 5.86 \text{ (3sf)} \end{aligned}$$

5.4 3D Pythagoras & Trigonometry

Question 41:

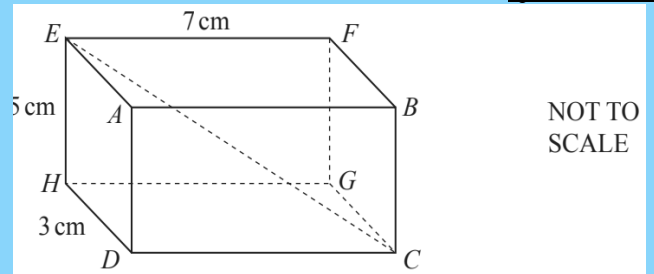

The diagram shows a cuboid. $HD = 3$ cm, $EH = 5$ cm and $EF = 7$ cm. Calculate

- (a) the length CE , [4]
- (b) the angle between CE and the base $CDHG$. [3]

Solution:

Part (a)

First consider triangle CHD

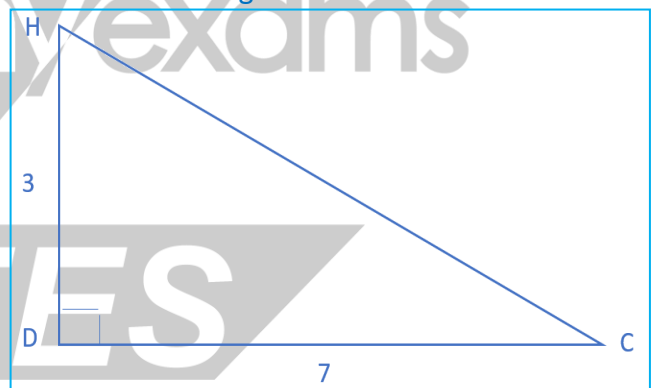

Calculate CH using Pythagoras'

$$\begin{aligned} CH^2 &= 3^2 + 7^2 \\ &= 58 \\ CH &= \sqrt{58} \end{aligned}$$

Now consider triangle CHE

5.3 Sine & Cosine Rule

Question 40:

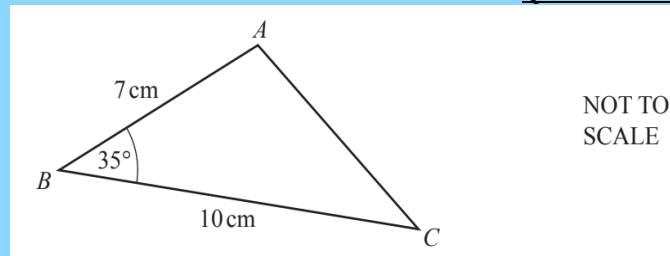

- (a) Calculate the area of triangle ABC . [2]
- (b) Calculate the length of AC . [4]

Solution:

Part (a)

Area of a triangle is

$$\begin{aligned} A &= \frac{1}{2} ab \sin C \\ A &= \frac{1}{2} \times 7 \times 10 \times \sin 35 \\ A &= 20.1 \text{ (3sf)} \end{aligned}$$

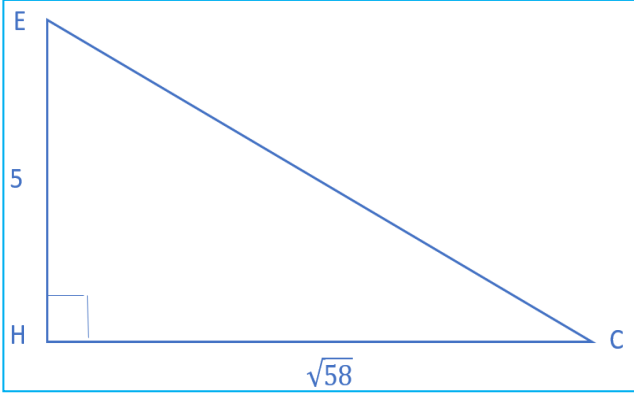

Find CE using Pythagoras'

$$\begin{aligned} CE^2 &= 5^2 + 58 \\ &= 83 \\ CE &= \sqrt{83} \\ &= 9.11 \end{aligned}$$

Part (b)

Considering triangle CHE again

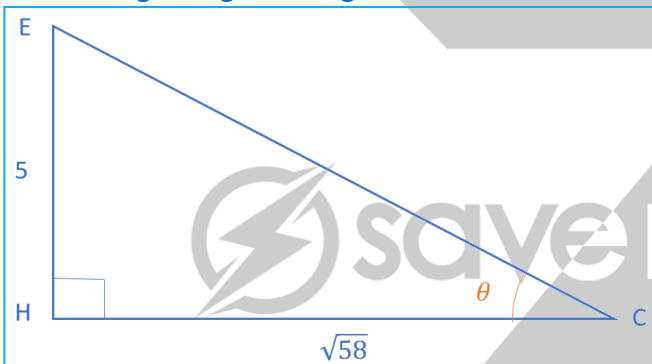

We now need to calculate angle θ . To do this we can use the tan relation

$$\tan \theta = \frac{\text{opp}}{\text{adj}}$$

Using our values

$$\begin{aligned} \tan \theta &= \frac{5}{\sqrt{58}} \\ \theta &= \tan^{-1} \frac{5}{\sqrt{58}} \\ &= 33.3^\circ \end{aligned}$$

6. MATRICES AND TRANSFORMATIONS

6.1 Vectors

Question 42:

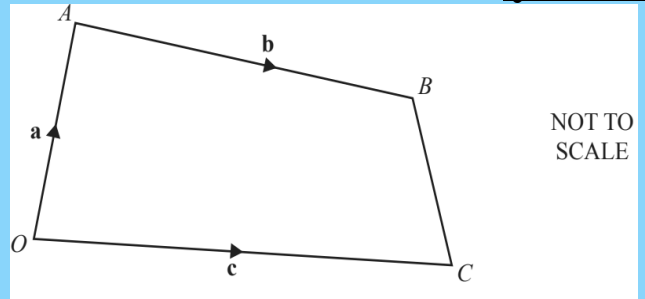

In the diagram, O is the origin, $\vec{OA} = \mathbf{a}$, $\vec{OC} = \mathbf{c}$ and $\vec{AB} = \mathbf{b}$. P is on the line AB so that $AP : PB = 2 : 1$. Q is the midpoint of BC . Find, in terms of \mathbf{a} , \mathbf{b} and \mathbf{c} , in its simplest form

- (a) \vec{CB} , [1]
- (b) the position vector of Q , [2]
- (c) \vec{PQ} . [2]

Solution:

Part (a)

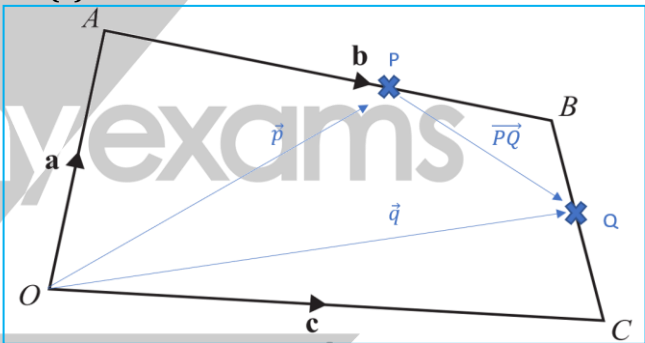

$$\vec{CB} = \vec{a} + \vec{b} + \vec{c}$$

Part (b)

$$\begin{aligned} \vec{q} &= \vec{c} + \frac{1}{2}\vec{CB} \\ &= \vec{c} + \frac{1}{2}(-\vec{c} + \vec{a} + \vec{b}) \\ &= \frac{1}{2}(\vec{a} + \vec{b} + \vec{c}) \end{aligned}$$

Part (c)

$$\begin{aligned} \vec{PQ} &= -\vec{p} + \vec{q} \\ \vec{p} &= \vec{a} + \frac{2}{3}\vec{b} \\ \rightarrow \vec{PQ} &= -\vec{a} - \frac{2}{3}\vec{b} + \frac{1}{2}(\vec{a} + \vec{b} + \vec{c}) \\ &= -\frac{1}{2}\vec{a} - \frac{1}{6}\vec{b} + \frac{1}{2}\vec{c} \end{aligned}$$

FOR MORE PAST PAPER QUESTIONS, VISIT
WWW.SAVEMYEXAMS.CO.UK

6.2 Transformations (Reflection, Enlargement, Rotation, Translation)

Question 43:

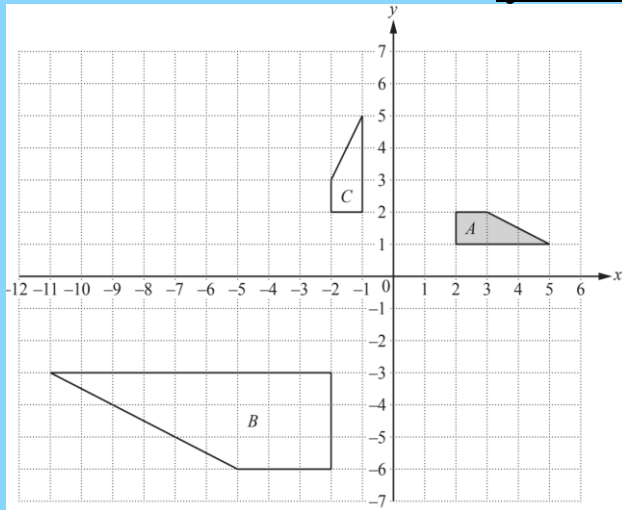

- (a) Draw the image of
- shape A after a translation by $\begin{pmatrix} -1 \\ 3 \end{pmatrix}$, [2]
 - shape A after a rotation through 180° about the point $(0, 0)$, [2]
 - shape A after the transformation represented by the matrix $\begin{pmatrix} 1 & 0 \\ 0 & -1 \end{pmatrix}$ [3]
- (b) Describe fully the **single** transformation that maps shape A onto shape B. [3]
- (c) Find the matrix which represents the transformation that maps shape A onto shape C [2]

Solution:

Part (a)(i)

This transformation represents a shift by 1 unit in the negative x direction and by 3 units in the positive y direction.

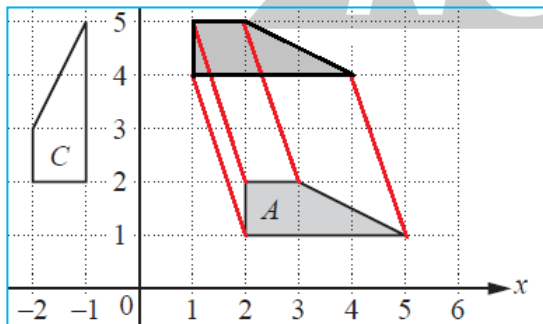

The vertices of the new shape are: $(1,4)$, $(1,5)$, $(2,5)$ and $(4,4)$.

Part (a)(ii)

We rotate the shape by 180° . This is essentially the same as reflecting the shape in line $y=-x$.

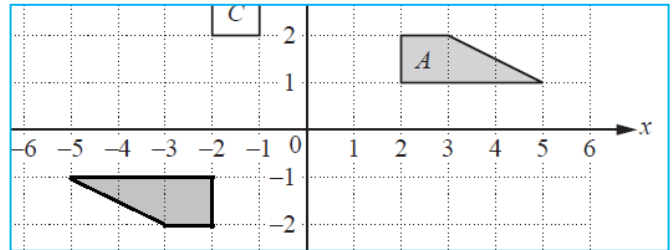

The vertices of the rotated shape are: $(-2,-1)$, $(-5,-1)$, $(-2,-2)$ and $(-3,-2)$.

Part (a)(iii)

This matrix transformation represents a reflection in the x-axis.

The x coordinate does not change, but the y coordinate flips sign.

$$\begin{pmatrix} 1 & 0 \\ 0 & -1 \end{pmatrix} \begin{pmatrix} x \\ y \end{pmatrix} = \begin{pmatrix} x \\ -y \end{pmatrix}$$

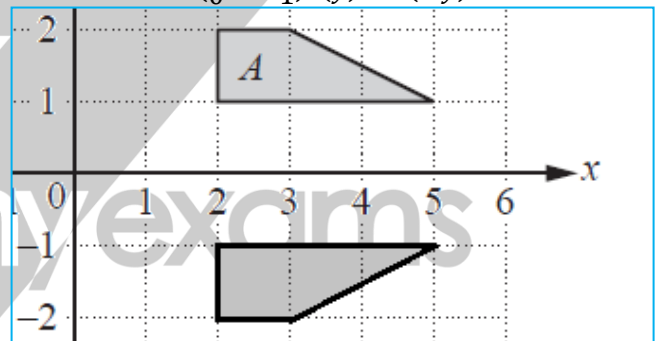

The vertices of the new shape are: $(2,-1)$, $(5,-1)$, $(2,-2)$ and $(3,-2)$.

FOR MORE PAST PAPER QUESTIONS, VISIT
WWW.SAVEMYEXAMS.CO.UK

Part (b)

When we join the corresponding vertices of shapes A and B, the lines cross at point (1,0).
 The distance from (1,0) to a vertex of shape B is three times as long as the distance from (1,0) to a corresponding vertex of shape A.
 This suggests that the scale factor of the enlargement is -3 (minus sign as the lines point in the opposite direction from (1,0)).

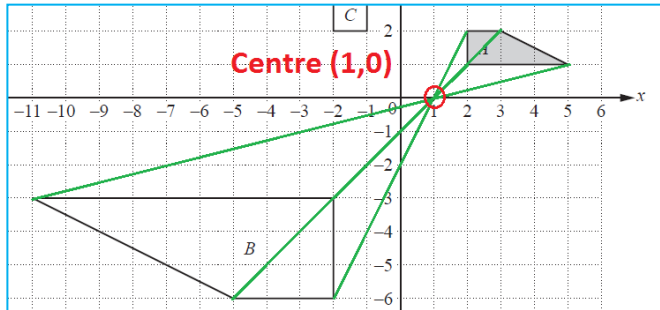

The transformation is an enlargement with centre (1,0) and the scale factor -3.

Part (c)

The transformation that maps shape A onto shape C is a rotation by 90° in anticlockwise direction.
 A general matrix for rotation looks like $\begin{pmatrix} \cos x & -\sin x \\ \sin x & \cos x \end{pmatrix}$ where x is an angle of anticlockwise rotation.

This matrix becomes $\begin{pmatrix} 0 & -1 \\ 1 & 0 \end{pmatrix}$ for $x = 90$

7. PROBABILITY

7.1 Probability

Question 45:

The probability of a cricket team winning or losing in their first two matches is shown in the tree diagram.

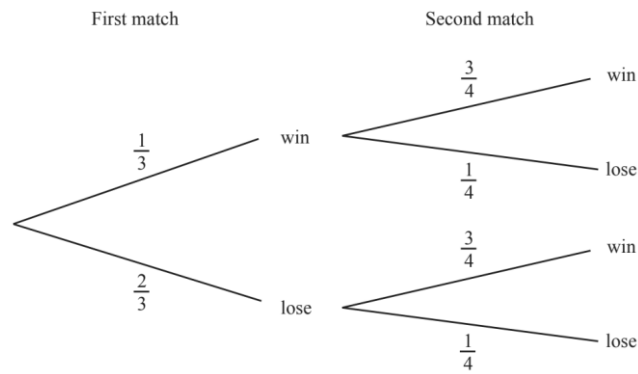

Find the probability that the cricket team wins at least one match. [3]

Solution:

The branches that result in at least one win for the cricket team are circled below:

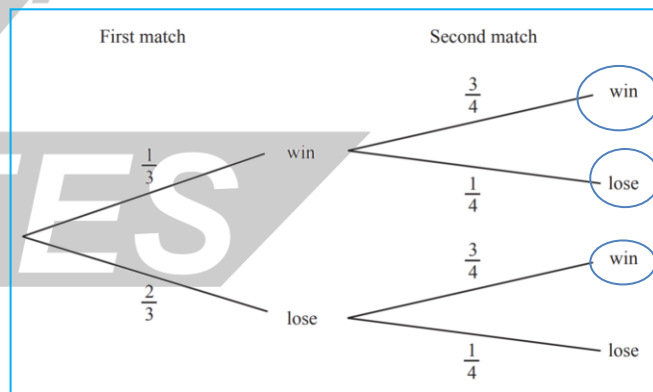

The end probability of each branch is the two probabilities multiplied, for example the top branch is

$$\frac{1}{3} \times \frac{3}{4} = \frac{1}{4}$$

6.3 Matrices

Question 44:

$$A = \begin{pmatrix} 0 & 1 \\ -8 & -4 \end{pmatrix} \quad B = \begin{pmatrix} 7 & 1 \\ 0 & -5 \end{pmatrix}$$

Calculate the value of $5|A| + |B|$, where $|A|$ and $|B|$ are the determinants of A and B . [2]

Solution:

Part (a)

To answer this question, we first need to find the determinant of A and B . The determinant $|X|$ of a matrix is calculated by $ad - bc$ where $X = \begin{pmatrix} a & b \\ c & d \end{pmatrix}$.

Using this we can calculate $|A|$ and $|B|$:

$$|A| = 0 \times -4 - 1 \times -8 = 8$$

$$|B| = 7 \times -5 - 0 \times -1 = -35$$

Substituting these values in gives us:

$$5|A| + |B| = 40 + -35 = 5$$

So, the answer is:

5

We need to add these probabilities together like so

$$\begin{aligned} \frac{1}{3} \times \frac{3}{4} + \frac{1}{3} \times \frac{1}{4} + \frac{2}{3} \times \frac{3}{4} \\ = \frac{1}{4} + \frac{1}{12} + \frac{1}{2} \\ = \frac{3}{12} + \frac{1}{12} + \frac{6}{12} \\ = \frac{10}{12} \\ = \frac{5}{6} \end{aligned}$$

FOR MORE PAST PAPER QUESTIONS, VISIT
WWW.SAVEMYEXAMS.CO.UK

8. STATISTICS

8.1 Histograms, Bar Charts, Pictograms, Scatter Diagrams & Frequency Distributions

Question 46:

Deborah records the number of minutes late, t , for trains arriving at a station. The histogram shows this information.

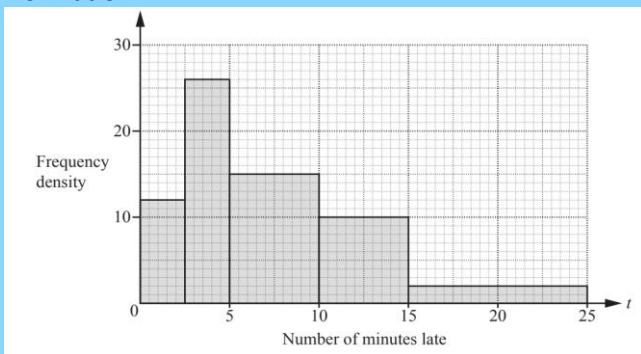

- (a) Find the number of trains that Deborah recorded [2]
- (b) Calculate the percentage of the trains recorded that arrived more than 10 minutes late. [2]

Solution:

Part (a)

We need to add the areas of the rectangles together
 $12 \times 2.5 + 26 \times 2.5 + 15 \times 5 + 10 \times 5 + 2 \times 10$
 $= 240$

Part (b)

Number of trains that arrived more than 10 minutes late is the area of the last 2 bars

$$5 \times 10 + 10 \times 2 = 70$$

This, as a percentage of the total, is

$$\frac{70}{240} \times 100\% = 29.2\%$$

8.2 Mean/Median/Mode/Range

Question 47:

Shahruk plays four games of golf. His four scores have a mean of 75, a mode of 78 and a median of 77. Work out his four scores. [3]

Solution:

The mean is the sum of the four scores divided by 4

$$\frac{s_1 + s_2 + s_3 + s_4}{4} = 75$$

The mode is the number that occurs most frequently, i.e. 2 or more of his scores must be 78. Let

$$s_3 = s_4 = 78$$

Where we have an even number of items, the median is the mean of the middle 2 numbers when put in rank order. Let the middle two scores be s_2 and s_3 . Thus, we have

$$\begin{aligned} \frac{s_2 + 78}{2} &= 77 \\ \rightarrow s_2 &= 76 \end{aligned}$$

We can now figure out s_1 from the mean

$$\begin{aligned} s_1 + 76 + 78 + 78 &= 4 \times 75 \\ \rightarrow s_1 &= 68 \end{aligned}$$

Final answer is

68, 76, 78, 78

8.3 Grouped Data - Mean/Modal Class & Drawing Histograms

Question 48:

The table shows the times, t minutes, taken by 200 students to complete an IGCSE paper.

Time (t minutes)	$40 < t \leq 60$	$60 < t \leq 70$	$70 < t \leq 75$	$75 < t \leq 90$
Frequency	10	50	80	60

- (a) By using mid-interval values, calculate an estimate of the mean time. [3]
 (b) On the grid, draw a histogram to show the information in the table. [4]

Solution:

Part (a)

The mean value is estimated by assuming that the time taken to complete an IGCSE paper for all students within a given group was equal to the mid-value of that group

(i.e. 50min, 65min, 72.5min, 82.5min).

We sum the products of the mid-value and the frequency of given group and then divide by the total number of students to get the mean estimate. The mean is therefore:

$$\begin{aligned}
 & \text{mean} \\
 &= \frac{50\text{min} \times 10 + 65\text{min} \times 50 + 72.5\text{min} \times 80 + 82.5\text{min} \times 60}{200 \text{ students}} \\
 & \text{mean} = 72.5\text{min}
 \end{aligned}$$

Part (b)

To get the right histogram, each bar needs to have an area equal to the frequency of the given group.

- The width of the first group is 20 and the frequency is 10, so the height of the bar is $10/20=0.5$ (red)
- The width of the second group is 10 and the frequency is 50, so the height of the bar is $50/10=5.0$. (blue)
- The width of the third group is 5 and the frequency is 80, so the height of the bar is $80/5=16$. (green)
- The width of the fourth group is 15 and the frequency is 60, so the height of the bar is $60/15=4.0$. (orange)

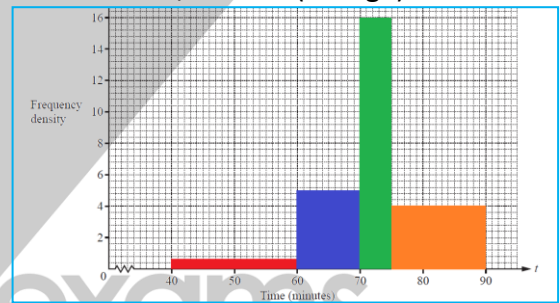

8.4 Cumulative Frequency & Frequency

Density Diagrams

Question 49:

The cumulative frequency diagram shows information about the trunk diameter, in metres, of 120 trees. Find:

- (a) the inter-quartile range, [2]
- (b) the 95th percentile, [2]
- (c) the number of trees with a trunk diameter greater than 3 metres. [2]

Solution:

Part (a)

Subtract the lower quartile from the upper quartile (as seen on graph below)

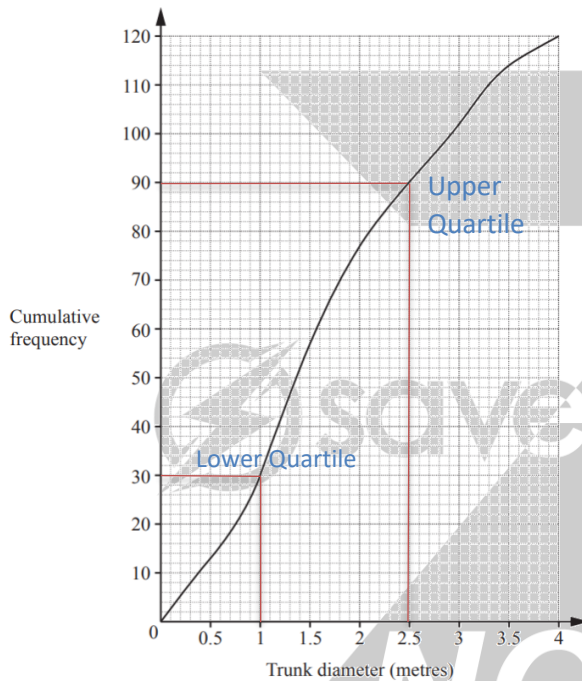

$$2.5 - 1 = 1.5$$

Part (b)

95% of 120 is

$$0.95 \times 120 = 114$$

Read this across and read off corresponding x value

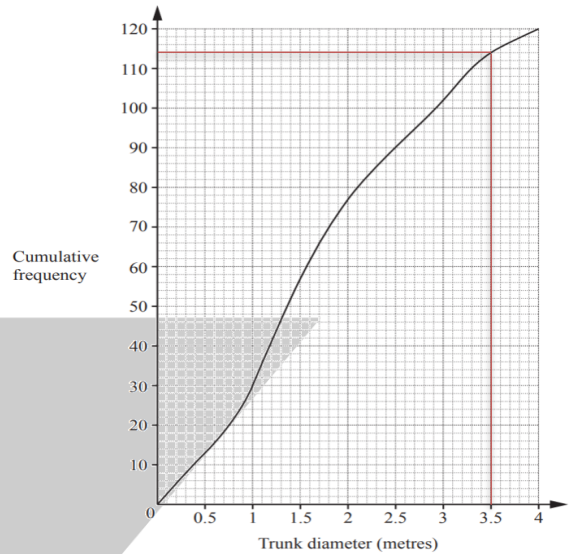

$$= 3.5$$

Part (c)

Read off y-value for 3 metres and subtract this from total number of trees (120).

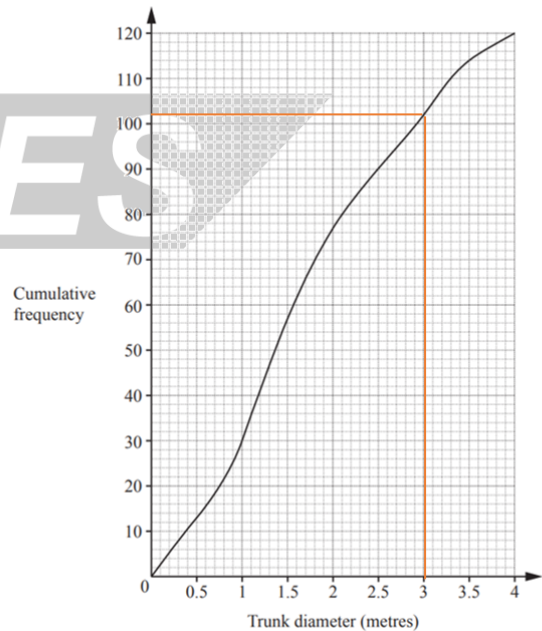

$$120 - 102 = 18$$

8.5 Correlation**Question 1:**

A company sends out ten different questionnaires to its customers.

The table shows the number sent and replies received for each questionnaire.

Questionnaire	A	B	C	D	E	F	G	H	I	J
Number sent out	100	125	150	140	70	105	100	90	120	130
Number of replies	24	30	35	34	15	25	22	21	30	31

- (a) Complete the scatter diagram for these results.
The first two points have been plotted for you. [2]
- (b) Describe the correlation between the two sets of data. [1]
- (c) Draw the line of best fit. [1]

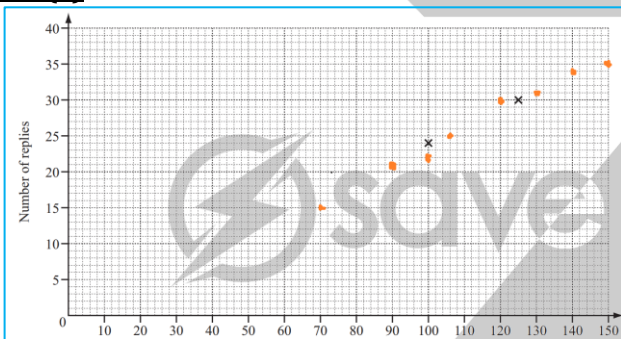
Solution:**Part (a)****Part (b)**

It is **positive** correlation.

This is because as the number of questionnaires sent out **increases**, the number of replies also **increases**.

Part (c)

The line of best fit is drawn in blue

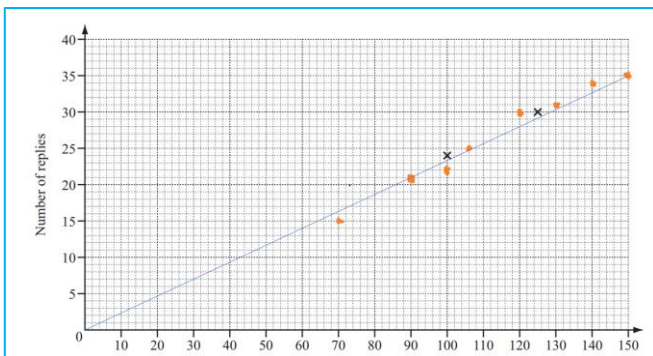

CIE IGCSE MATHS//0580

 save my exams



© Copyright 2018 by Savemyexams and ZNotes

This document contain images and excerpts of text from educational resources available on the internet and printed books. If you are the owner of such media, text or visual, utilized in this document and do not accept its usage then we urge you to contact us and we would immediately replace said media.

No part of this document may be copied or re-uploaded to another website without the express, written permission of the copyright owner. Under no conditions may this document be distributed under the name of false author(s) or sold for financial gain; the document is solely meant for educational purposes and it is to remain a property available to all at no cost. It is currently freely available from the website www.znotes.org

This work is licensed under a Creative Commons Attribution-NonCommercial-ShareAlike 4.0 International License.

WWW.

NOTES
.ORG